



Straw Blower

Model B70



*B70 Straw Blower
Straight Pull Trailer.
(B70T)*

The FINN B70 Straw Blower is an ideal performer for all mid-size mulching needs. Designed to handle a wide variety of mulching material, the B70 gives you the high productivity and dependability that is essential for tackling home sites, industrial and commercial projects, and highway roadsides.

Power & Performance.

The B70 is capable of handling 6-7 tons per hour, while providing maximum operator convenience. The feed tray is adjustable in height and length, providing the most convenient positioning for feeding from your vehicle. The discharge spout is equipped with a tension device for easy one hand operation control. The large operator platforms on the trailer model allow control of the discharge spout, as well as feeding from either side of the machine.

When The Going Gets Tough.

The B70 Straw Blower features independent torsion axle suspension and large 15" wheels, providing easy trailing on rough or uneven terrain. Electric brakes are standard equipment. The over-center clutch is also standard, eliminating shock load transmissions to the engine, starter, and other driveline components. The B70 Straw Blower is

also available as a skid model - an excellent option when you want a spreader and mulcher located on the same vehicle.

As the world leader for over 70 years in the design and manufacture of innovative, quality equipment for the erosion control industry, FINN Corporation is committed to your complete satisfaction.



B70, Right Hand Feed, Straw Blower Skid Mounted. (B70S)

Model shown may include optional equipment.



Straw Blower

Model B70 with Tier 4Final Diesel Engine

B70T TRAILER

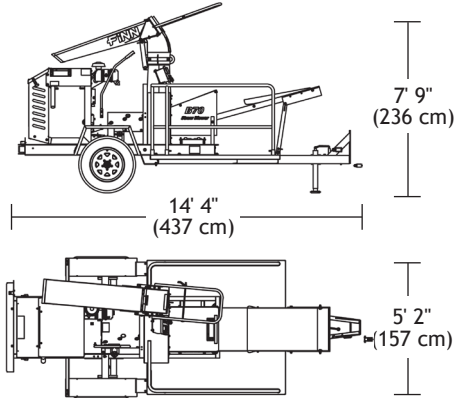

B70S SKID MOUNT

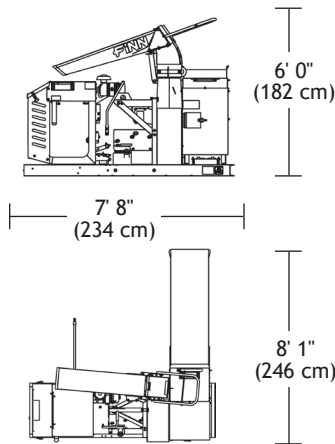

FINN MODEL B70 TECHNICAL SPECIFICATIONS

POWER	Yanmar 3TNV88C-DYEM, 35.1hp (26.2kw), 3 cylinder water cooled diesel engine with over-center clutch. Tier 4Final. 1.642L
ENGINE SAFETY..... SYSTEM	Low oil pressure, electronic engine control and monitoring
CAPACITY.....	Up to 7 tons of hay or straw per hour
FUEL TANK	11 gallon (41.6 liter)
CAPACITY	
BLOWER.....	Dynamically balanced, 21" (53 cm) diameter fan with 6 blades developing a discharge velocity greater than 150 mph (240 km/h)
RANGE.....	60 ft. (18 m) in still air
FEED.....	Manual
BEATER CHAMBER	3.5 cu. ft. (99 liter) with removable beater chains
DISCHARGE SPOUT	Block bearing mounted. 360 degrees horizontal rotation and 70 degrees vertical travel
TRAILER OPTION	Independent suspension rubber torsion axle, electric brakes, ST205/75015 load range C tires, fenders, D.O.T highway lights, dual skid proof operator platforms, parking jack, 2" (5 cm) ball or heavy duty lunette ring
FEED TRAY	Folding tray, adjustable height to meet bed of supply vehicle
DRIVE.....	Blower fan in-line coupled to over-center clutch with flexible coupling and two pillow block bearings
WEIGHT	B70S 1,700 lbs. (771 kg) B70T 2,360 lbs. (1070 kg)

FINN Corporation has a policy of continuous product improvement, and reserves the right to change design and specifications without notice.

FINN Design® Logo is a trademark of FINN Corporation.



9281 LeSaint Drive • Fairfield, OH 45014-5457
Toll Free 800.543.7166 / 513.874.2818
FINNcorp.com