



SMARTER WAYS TO WORK™



MBH6

Material Blower

The new MBH6 Material Blower is designed with simplicity and reliability in mind for landscape and erosion control contractors. Its simplified control system, with multi-language capability and streamlined engineering design, make it a dependable workhorse for bark, mulch, compost and soil blend applications. This mid-size Material Blower is easy to operate, maintain and troubleshoot, leading to vital uptime and optimal productivity. Products can be applied on virtually any terrain, even in wet conditions, and the MBH6 can be especially profitable when accessing hard-to-reach areas.

Saving Time & Labor & Material = Profitability.

Save labor by avoiding the manual work of spreading material using wheelbarrows and rakes. Two workers alone can apply 15 cubic yards of mulch per hour with the MBH6, depending on job conditions and material. This means that you can make more money by doing more jobs in a day and putting your extra laborers who were moving product with wheelbarrows and rakes to work for you on more profitable projects! Additionally, you can save as much as 25% in product due to the ability to blow a smooth, even layer, rather than the thick and thin irregular application that happens when product is spread manually.

Features & Benefits

- Full 6 cubic yard material hopper for increased productivity and clear-cut job costing
- Simplified control system for ease of operation, ease of training, and reliable performance
- Simplified unit design for critical uptime and easier maintenance and troubleshooting
- Lightweight design for increased payload capacity and more versatile towing options
- Fuel tank sized to run machine for at least 6.6 hours

Features & Benefits (continued)

- Side mounted engine with an open design for enhanced maintenance access
- Convenient hose reel, hydraulically powered, and provided with 150 feet of 4-inch blower hose
- Electric tarp standard to help meet DOT laws for load coverage
- Optional hose hookup water injection system for dust suppression in particularly dry conditions or with particularly dry materials
- Centralized lubrication points for increased serviceability
- Radio remote with visible set points for engine/blower speed and feeder speed

The MBH6 Material Blower completes the FINN material blower line which also includes the BB302 (1.5 yd³ box), MBX10 (10 yd³ box), MBX16 (16 yd³ box), and the MBX22 (22 yd³ box). FINN Material Blowers are covered with an industry leading 1 year/1,200 hour warranty, whichever comes first. All FINN machines are proudly made in the USA.

Applications



Erosion Control

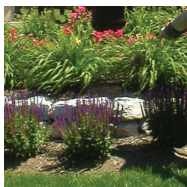

Landscape

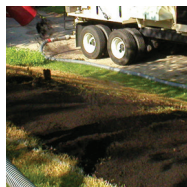

Post-Construction



Highway / Oil / Gas / Pipeline



Golf Courses

**MBH6
Material Blower**

Technical Specifications

MBH6 Material Blower

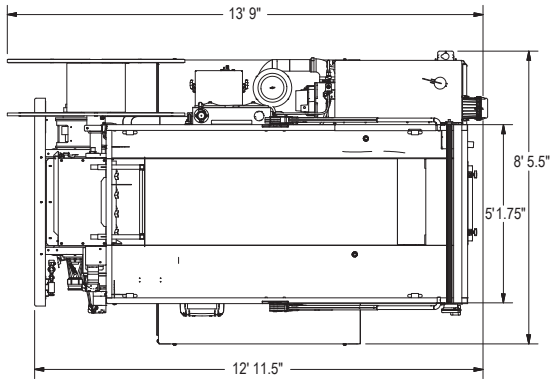

MBH6 Material Blower

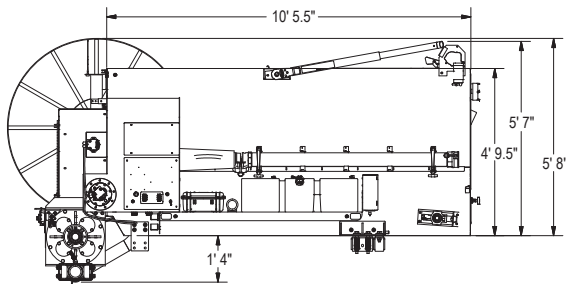

Power	Yanmar 4TNV98C (3.3L) Tier 4 Final Diesel, 67HP (50kW)
Engine Safety System	Low Oil Pressure, Electronic control and monitoring
Capacity	6 cubic yd. (4.6m ³)
Hose Reel Capacity	150ft. (45.7m)
Fuel Tank Capacity	27 Gallon (102 Liter)
Blower	725 CFM @ 12 psi (20.5cm ³ @82.7kPa)
Empty Weight*	Skid: 8,600 lbs. (3,900.9 kg)
Working Weight*	Skid: 13,500 lbs. (6,123.5 kg)

* Working weights are approximate and do not include options or stored materials. Based on material at 850 lbs. / cu. yd.

FINN Corporation has a policy of continuous product improvement, and reserves the right to change design and specifications without notice.

HydroSeeder® and the FINN Design® Logo are registered trademarks of FINN Corporation.



9281 LeSaint Drive | Fairfield, OH 45014-5457
Toll Free 800.543.7166 | 513.874.2818

Follow us on: [f](#) [t](#) [in](#) [@](#)
www.FINNcorp.com